

Bei Ersatzteilanforderung bitte immer die vollständige Ersatzteil-Nr. angeben. · Please order the wanted spare part with the complete spare part item number.  
Pour commander des pièces de rechange, ne pas oublier de donner le Numéro d'Article de la pièce demandée. · 订购配件时请附上完整的配件号码。

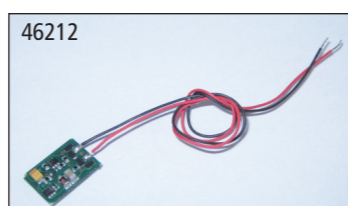

### ERSATZTEILE BR 798 SCHIENENBUS\_N

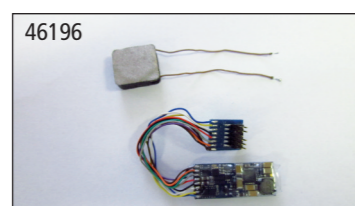
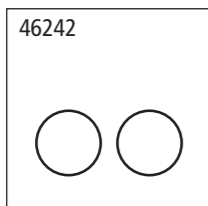
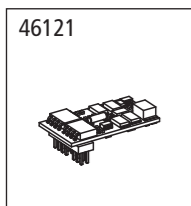
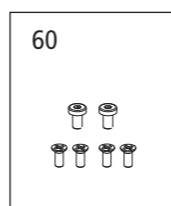
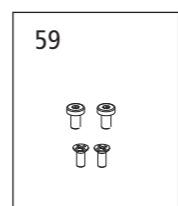
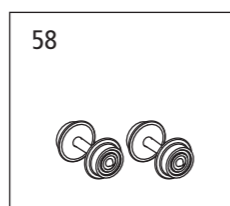
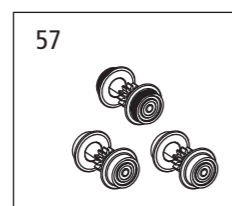
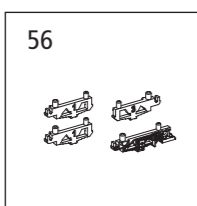
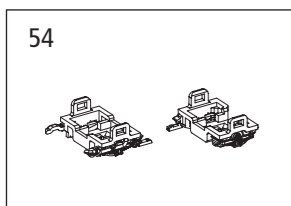
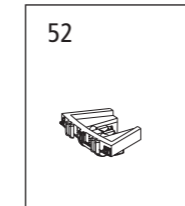
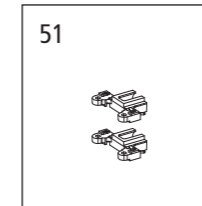
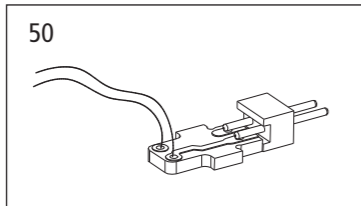
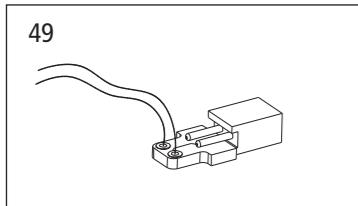
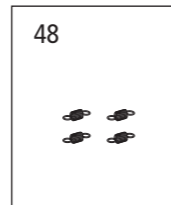
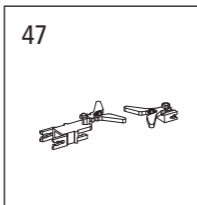
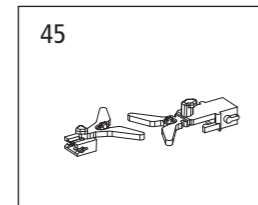
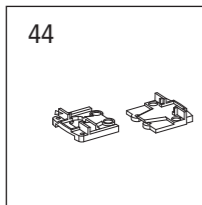
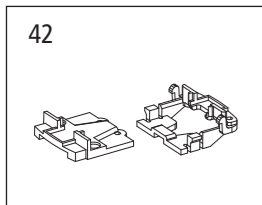
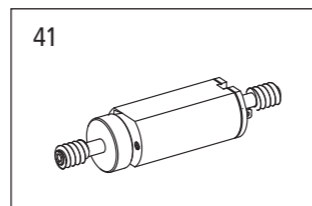
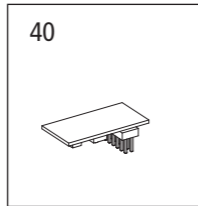
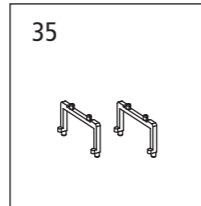
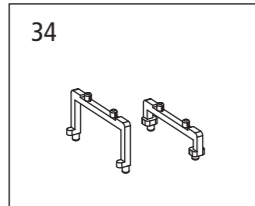
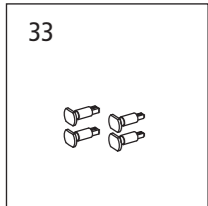
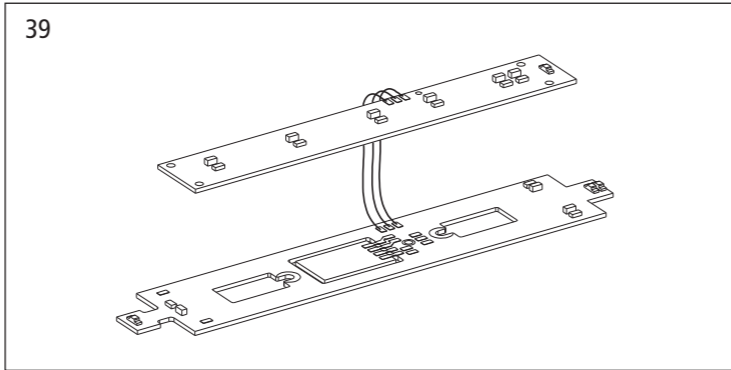
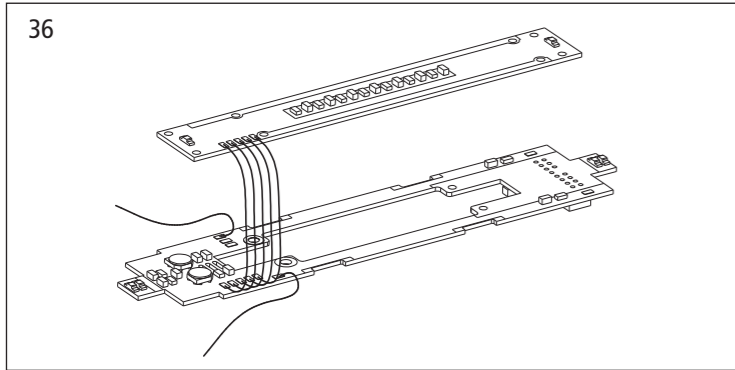
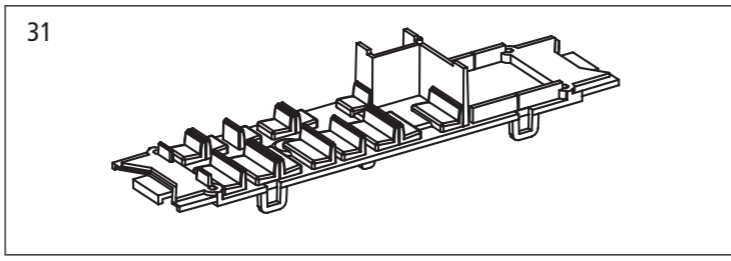
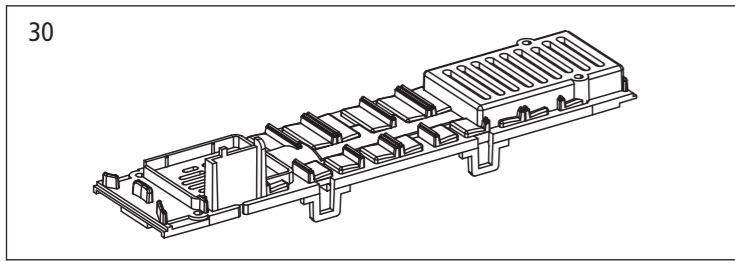

Spare parts · Pièces détachées · Parti di ricambio · Repuestos · 配件  
Reserveonderdelen · Części zamienne · Запасные части · Náhradní díly

包装及说明书内包含重要信息, 请保留备用

PluX16  
# 40250 Gleichstrom DC 0-12 V

Bei Ersatzteilanforderung bitte immer die vollständige Ersatzteil-Nr. angeben. · Please order the wanted spare part with the complete spare part item number.  
Pour commander des pièces de rechange, ne pas oublier de donner le Numéro d'Article de la pièce demandée. · 订购配件时请附上完整的配件号码。

